

# SPIDER 22.10

SPINHOOGWERKER



**PL** / **TFORM**  
B A S K E T

 **Totaallift**

**SAMENWERKEN OP HOOG NIVEAU**

# Spinhoogwerker Platform Basket

## Specificaties Spider 22.10



Technische specificaties		STD	E	ED
Maximale werkhogte	m		21,70	
Platformhoogte	m		19,70	
Maximale reikwijdte	m		10,30	
Rotatie	°		365	
Afmetingen werkbak	m		1,50 x 0,70	
Werkbak rotatie	°		90+90	
Maximale werkbak bak capaciteit	Kg		230	
Lengte ingeklapt (zonder werkbak)	m		5,97 (5,28)	
Minimum breedte ingeklapt	m		0,98	
Minimum hoogte ingeklapt	m		2,06	
Voetafdruk steunpoten	Breed Smal	m	3,87 x 3,94 2,57 x 5,05	
Maximale hellingsgraad	°/%		16 ° (29%)	
Maximale zijdelingse hellingsgraad	°/%		17 ° (31%)	
Maximale rijnsnelheid	Km/u	1,5	0,8	1,5
Gewicht		STD	E	ED
Gewicht in werkende toestand*	Kg	2.980*	3.260*	3.260*
Gronddruk ingeklapte machine	KN/m2	2,94	3,21	3,21
Gronddruk op steunpoten	KN/m2	1,91	2,09	2,09
Maximale puntbelasting	KN	21	23	23
Aandrijving		STD	E	ED
Diesel motor Z602 Kubota	PK/tpm	14/3.600	-	14/3600
Elektrische motor 220 Vac	CV/KW	3/2,2	3/2,2	-
Elektrische motor 24 Vdc	CV/KW	-	7,4/5,5	7,4/5,5
Batterij-capaciteit	24Vdc Loodzuur 24Vdc Lithium-ion	Ah	- 2x210 400	1x210 300
Batterijlader	Loodzuur Lithium-ion	Ah	- 45 100 / 50	45 100/ 50

\* Kan verschillen op basis van de configuratie

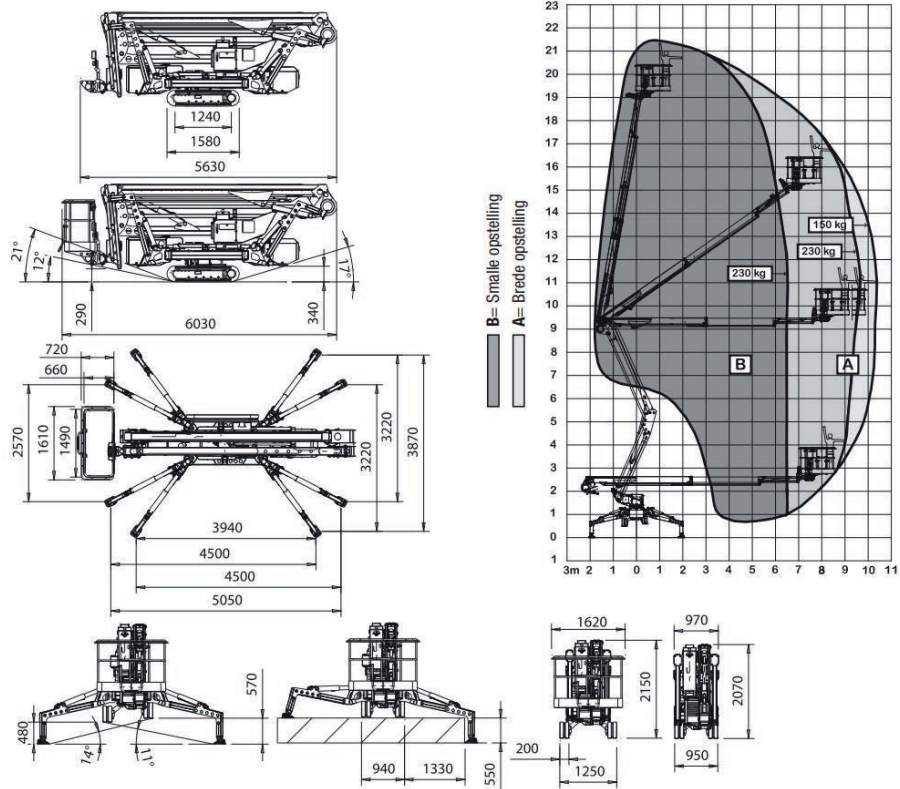

### Licht en hoge prestaties

- Ultra-licht en makkelijk te vervoeren
- 230 kg capaciteit in de werkbak
- Elektrische batterij of Hybride-versie op aanvraag
- Eenvoudige toegang voor onderhoud
- Radiografische bediening standaard
- Automatische afstempeling en stabilisatie
- Lucht,water en 220Vac-aansluitingen in de werkbak
- Werkbak uitwisselbaar met lier (optioneel)
- Hydraulisch verstelbare rupsen
- Elektrisch werken op 220V
- Bakrotatie standaard



