



# EPT20-18EA

## Electric Pallet Truck 1.8t

- **Delivery Truck:** The Last Mile Solution Truck  
Customised for Half Pallet Handling, Dock Tail Trailer
- **Applicable Industry:** Mailing, Beverage, Food, Retail, Convenient Stores, etc.

EP EQUIPMENT CO.,LTD  
[www.ep-ep.com](http://www.ep-ep.com)



# Electric Pallet Truck 1.8t EPT20-18EA

Distinguishing mark				
1.1	Manufacturer			EP
1.2	Model designation			EPT20-18EA
1.3	Drive unit			Electrics
1.4	Operator type			pedestrian
1.5	rated capacity	Q	kg	1800
1.6	Load center distance	c	mm	600
1.7	Load distance	x	mm	945
1.9	Wheelbase	y	mm	1270
Weight				
2.1	Service weight (include battery)		kg	285
2.2	Axle loading, laden driving side/loading side		kg	770/1315
2.3	Axle loading, unladen driving side/loading side		kg	230/55
Types,Chassis				
3.1	Tyre type driving wheels/loading wheels			polyurethane/ polyurethane
3.2	Tyre size, driving wheels (diameter×width)		mm	Φ230x75
3.3	Tyre size, loading wheels (diameter×width)		mm	Φ74x88 / Φ80x60
3.4	Tyre size, caster wheels (diameter×width)		mm	Φ85x48
3.5	Wheels, number driving, caster/loading (x=drive wheels)		mm	1x+2/2 / 1x+2/4
3.6	Track width, front,driving side	b <sub>10</sub>	mm	435
3.7	Track width,rear,loading side	b <sub>11</sub>	mm	390/495/535
Dimensions				
4.4	Lift height	h <sub>3</sub>	mm	108
4.9	Height drawbar in driving position min./max.	h <sub>14</sub>	mm	715 / 1200
4.15	Lowered height	h <sub>13</sub>	mm	85
4.19	Overall length	l <sub>1</sub>	mm	1625
4.20	Length to face of forks	l <sub>2</sub>	mm	475
4.21	Overall width	b <sub>1</sub> / b <sub>2</sub>	mm	645
4.22	Fork dimensions	s/ e/ l	mm	50x150x1150
4.25	Outside width of the forks	b <sub>5</sub>	mm	540/645/685
4.32	Ground clearance, center of wheelbase	m <sub>2</sub>	mm	35
4.34.1	Aisle width for pallets 1000 × 1200 crossways	Ast	mm	1720
4.34.2	Aisle width for pallets 800 × 1200 lengthways	Ast	mm	1920
4.35	Turning radius	Wa	mm	1465
Performance data				
5.1	Travel speed, laden/ unladen	km/ h	km/h	5.5/6
5.2	Lifting speed, laden/ unladen		m/ s	0.051/ 0.060
5.3	Lowering speed, laden/ unladen		m/ s	0.032/ 0.039
5.8	Max. gradeability, laden/unladen		%	6/16
5.10	Service brake type			Electromagnetic
Electric-engine				
6.1	Drive motor rating S2 60 min		kW	1.1
6.2	Lift motor rating at S3 15%		kW	0.84
6.3	The maximum allowed size battery		mm	269x182x300
6.4	Battery voltage/nominal capacity K20		V/ Ah	2x 12/85
6.5	Battery weight		kg	25 x2
Addition data				
8.1	Type of drive control			AC
10.5	Steering type			Mechanical
10.7	Sound pressure level at the driver's ear		dB(A)	74

If there are improvements of technical parameters or configurations, no further notice will be given.  
The diagram shown may contain non-standard configurations.





- World's 1st Half Pallet Truck
- High Traction, Indoor and Outdoor Perfect Handling
- Long Battery Running Time, Larger Battery Installment Option, Full day Job Handling
- Small Turning Radius, Excellent Maneuverability Inside Trailer
- On-board Charger, Easy to Charge
- Customized Solution Available

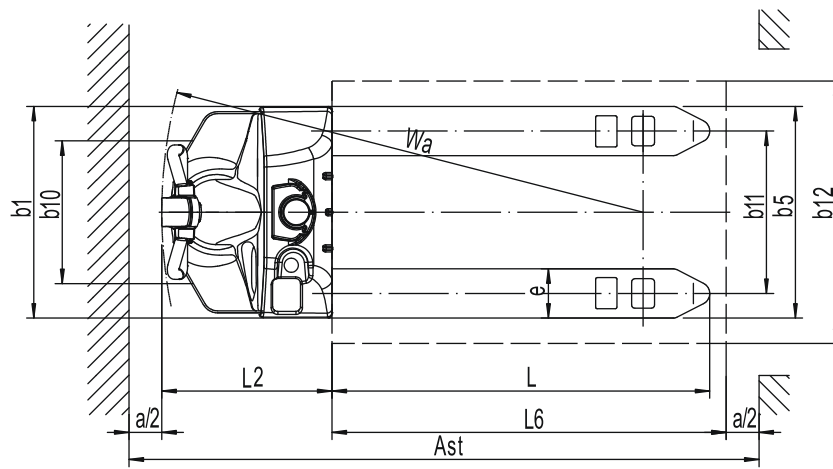
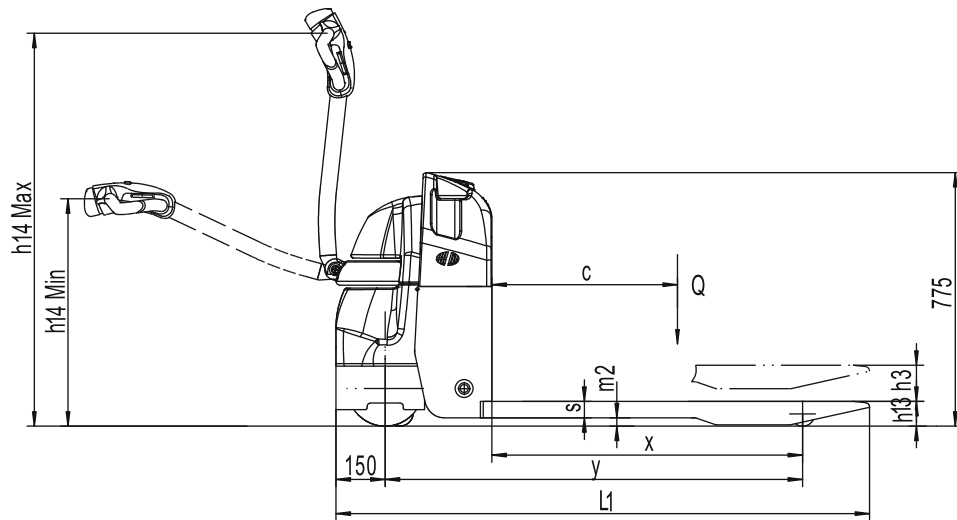

Solution Packages:

